



Assembly Guide

It's as easy as 1, 2, 3!

FAZTEK
INDUSTRIAL SOLUTIONS

Faztek's General Assembly Instructions

The following instructions are to assist you in assembling your projects. Below you will find detailed information on how to assemble each type of fastening method and basic accessories. Additionally, you will find helpful hints, tips, and basic order of operation when assembling your project.

To see similar type applications in the completed state, go to www.faztek.net. For any questions or additional information, contact the Faztek Inside Sales Team at **260-482-7544** or send an email to insidesales@faztek.net.

Table of Contents

Basic Order of Operation	4
Anchor Fastener Assembly	5
End Fastener Assembly	6
T-Anchor Fastener Assembly	7
Machiningless Fastener Assembly	8
Corner Bracket/Gusset Assembly	9
Joining Plate Assembly	10
Door Track Assembly	11
Panel Stiffener Assembly	12
Panel Gasket Assembly	13
T-Slot Cover Assembly	14
Wire Edging Assembly	15
Door Seal Assembly	16
Panel Retainer Assembly	17
Mesh Retainer Assembly	18

Basic Order of Operation

Step 1: Print and organize drawings and bill of materials



Step 2: Unpack project and organize project

- 2a. Bars in order according to tag numbers
- 2b. Panels in order according to tag numbers
- 2c. Parts grouped by part type



Step 3: Pre-load all brackets and plates



Anchor Fastener Assembly



Barrel fastener to be used in conjunction with the counterbore machining service.

Tools needed:

- 15 series: 13TL1202 - 1/4" ball end t-handle allen wrench
- 10 series: 13TL1201 - 3/16" ball end t-handle allen wrench
- Metric: 13TL1208 - M6 ball end t-handle allen wrench

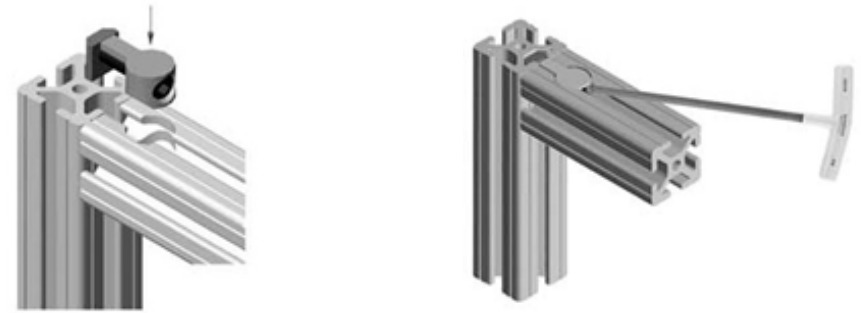

Instructions

- Step 1: Align the two extrusions at a 90deg angle
- Step 2: Drop the anchor into the counterbore on one extrusion and the connected t-nut in the slot of the other extrusion
- Step 3: Position extrusions and tighten fasteners

End Fastener Assembly



Screw & butterfly clip combination used to create a non-rotating 90deg connection. To be used in conjunction with tapping and access hole machining services.

Tools needed:

- 15 series: 13TL1202 - 1/4" ball end t-handle allen wrench
- 10 series: 13TL1201 - 3/16" ball end t-handle allen wrench
- Metric: 13TL1207 - M5 ball end t-handle allen wrench

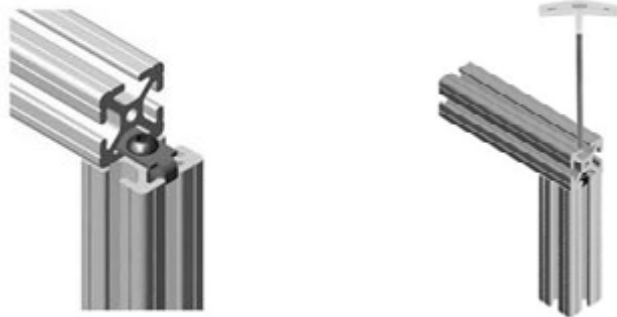

Instructions

- Step 1: Put the bolt thru the clip and thread into the tapped extrusion
- Step 2: Join the two extrusions by sliding the end fastener into the T-Slot of the mating extrusion
 - 2a: Be sure the access hole is aligned with the bolt head to allow access for the tool
- Step 3: Tighten fastener with tool thru the access hole

T-Anchor Fastener Assembly



Barrel fastener to be used in conjunction with the counterbore machining service for "SM" type material only.

Tools needed:

- 15 series: 13TL1201 - 3/16" ball end L-handle allen wrench

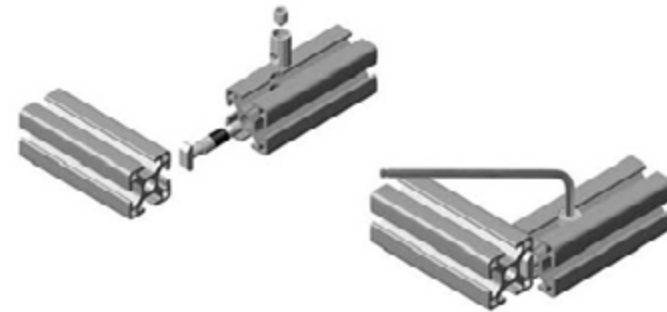

Instructions

- Step 1: Insert barrel into the counterbore of one extrusion
- Step 2: Insert the "T" bar w/ spring into the extrusion hole
- Step 3: Position extrusions and tighten fasteners

Machiningless Fastener Assembly



A mating block to allow two extrusions to be joined without machining.

Tools needed:

- 15 series: 13TL1201 - 3/16" ball end t-handle allen wrench
- 10 series: 13TL1203 - 5/32" ball end t-handle allen wrench
- All series: 3/8" drive socket wrench w/ 1/2" socket

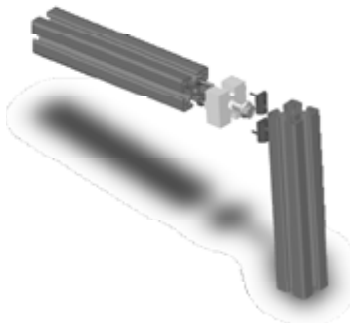

Instructions

- Step 1: Drop self tapping bolt into counterbore on plate and attach to one end of extrusion
- Step 2: Align the two extrusions at a 90deg angle
- Step 3: Drop bolt and t-nut into counterbore on plate and tighten bolt

Corner Bracket & Corner Gusset Assembly



Machined bracket to join two extrusions in the corner of the profiles.

Tools needed:

- 15 series: 13TL1201 - 3/16" ball end t-handle allen wrench
- 10 series: 13TL1203 - 5/32" ball end t-handle allen wrench
- Metric: 13TL1207 - M5 ball end t-handle allen wrench
- * Hardware sold separately



Instructions

- Step 1: Insert screw thru bracket and thread slightly into t-nut
- Step 2: Slide bracket with loaded hardware into the slot of the extrusion
- Step 3: Align to desired position and tighten fasteners

Joining Plate Assembly

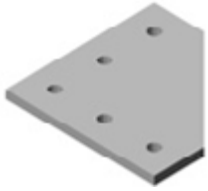

Machined plate to join two extrusions on the face of the profiles.

Tools needed:

- 15 series: 13TL1201 - 3/16" ball end t-handle allen wrench
- 10 series: 13TL1203 - 5/32" ball end t-handle allen wrench
- Metric: 13TL1207 - M5 ball end t-handle allen wrench
- * Hardware sold separately



Instructions

- Step 1: Insert screw thru bracket and thread slightly into t-nut
- Step 2: Slide bracket with loaded hardware into the slot of the extrusion
- Step 3: Align to desired position and tighten fasteners

Door Track Assembly

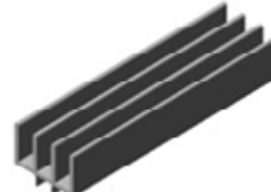

A profile that snaps into an extrusion T-Slot creating mini-slots for sliding doors.

Tools needed:

- All series: Rubber mallet

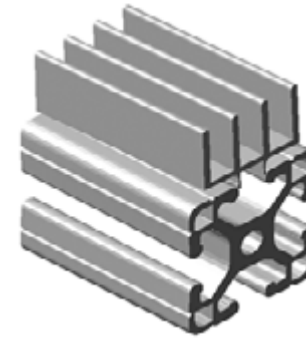

Instructions

- Step 1: Set the track over the T-Slot of the desired extrusion
 - 1a. Door track with bumps in the track are lower and the track without bumps is the upper
- Step 2: Start from one end and pound in with a rubber mallet

Panel Stiffener Assembly



An aluminum profile that snaps on the edge of a plastic panel to improve the rigidity, as well as an option for a built in handle.

Tools needed:

All series: Rubber mallet

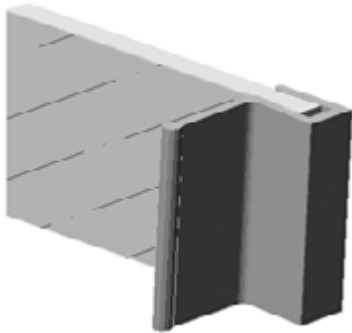

Instructions

- Step 1: Set the stiffener over the edge of the panel
- Step 2: Start from one end and pound onto the panel with a rubber mallet

Panel Gasket Assembly



Molded rubber used to wedge the plastic panel against the T-Slot to prevent rattling.

Tools needed:

- 1. Cutter

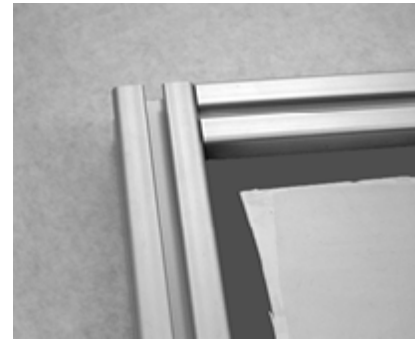

Instructions

Step 1: Set the small section of the gasket and press it into the start of one side of the panel with the top of the gasket angled up against the panel.

- 1a. Gasket is to be installed on the outside of the guard

Step 2: Press the gasket in all the way along the side

Step 3: Snip the back of the gasket to turn the corner and continue along the remaining sides

T-Slot Cover Assembly



Molded plastic used to cover the T-Slot to keep dirt out or to give a clean, smooth look.

Tools needed:

All series: Cutter

All series: Rubber mallet

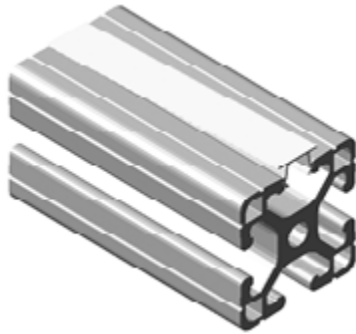

Instructions

Step 1: Cut the cover to the length of the given extrusion

Step 2: Press into one side of the T-Slot of the extrusion

Step 3: Press or pound the cover all the way to the other end of the profile

Wire Edging Assembly

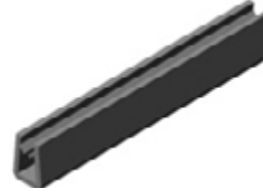

A rubber coated metal used to form on the edge of a sharp edge of a plastic or wire panel.

Tools needed:

All series: Cutter

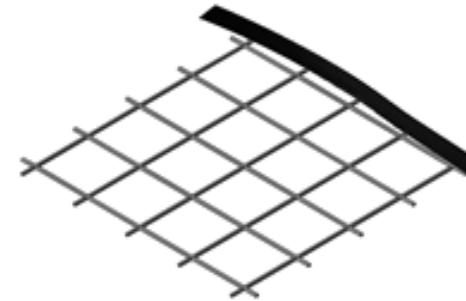

Instructions

Step1: Cut the wire edging to the length of the panel/opening being edged

Step 2: Press onto one end of the panel or the opening being edged

Step 3: Press the edging on the rest of the panel or the opening being edged

Door Seal Assembly



Molded rubber used to create a seal between a door and the door jams.

Tools needed:

All series: Cutter



Instructions

- Step 1: Cut the seal to the length of the given extrusion
- Step 2: Press into one side of the T-Slot of the extrusion
- Step 3: Press the seal all the way to the other end of the profile

Panel Retainer Assembly

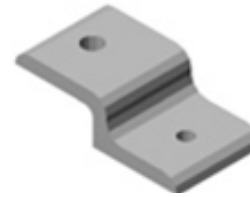

"S" shaped bracket used to add additional stiffness and security to a plastic panel.

Tools needed:

- 15 series: 13TL1201 - 3/16" ball end t-handle allen wrench
- 10 series: 13TL1203 - 5/32" ball end t-handle allen wrench
- Metric: 13TL1207 - M5 ball end t-handle wrench
- * Hardware sold separately

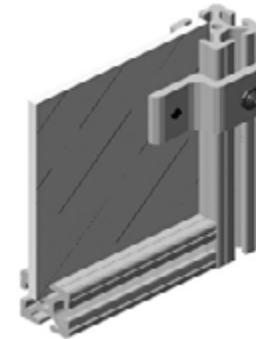

Instructions

- Step 1: Insert screw thru hole of upper hole in bracket and thread slightly into t-nut
- Step 2: Slide bracket with loaded hardware into the T-Slot of the extrusion
- Step 3: Position tapped hole of retainer with the access hole in the plastic panel
- Step 4: Insert bolt thru the plastic panel and thread into the retainer

Mesh Retainer Assembly



“S” shaped bracket used to add additional stiffness and security to a mesh panel.

Tools needed:

- 15 series: 13TL1201 - 3/16” ball end t-handle allen wrench
- 10 series: 13TL1203 - 5/32” ball end t-handle allen wrench
- Metric: 13TL1207 - M5 ball end t-handle wrench



Instructions

- Step 1: Insert screw thru hole of upper hole in bracket and thread slightly into t-nut
- Step 2: Slide bracket with loaded hardware into the T-Slot of the extrusion
- Step 3: Position slotted hole of retainer with an open square in the wire panel
- Step 4: While holding the backing plate against the back of the mesh panel, insert bolt thru the slotted hole of the retainer and thread into the backing plate

LET FAZTEK DO THE ASSEMBLY WORK FOR YOU!

Assembled on our floor

or

Assembled on your floor

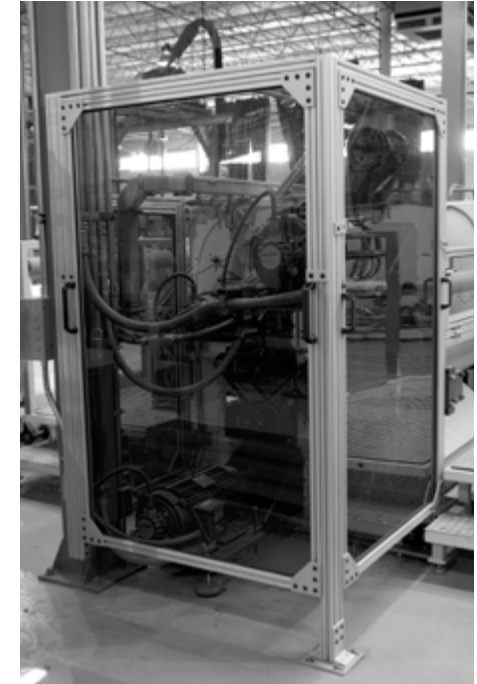

Our team is to help you with all of your assembly needs:

- **Kit Form Projects:** Our team tags, inspects, and ensures your project is ready for your team to assemble it.
- **Sub-Assembled Projects:** Our team will put together sections of your project, so your team will be able to quickly attach each section together.
- **Full Assembled Projects:** If your guard can fit on a pallet fully assembled, our team will build it and ship it to you complete. Once it arrives it's as simple as installing it.
- **On-Site Installation:** Our team takes care of your entire project from start to finish by coming to your facility and building it on site for you. This saves your team time and money by allowing your team to work on other in house projects.



Our Mission

Faztek, LLC recognizes that our primary mission is to provide our customers with custom industrial solutions through innovative designs, quality products, and dependable service within a reasonable time frame at an appropriate price. We also recognize that our primary asset is our employees and accordingly, we provide them with quality training, innovative techniques, and appropriate advancement opportunities.

Our Story

Faztek has evolved from a standard commodity aluminum extrusion supplier into a full-service industrial solutions provider. By expanding our product offering, we have been able to offer quality service and multiple types of products that can be combined and customized to meet specific customer needs. We work directly with customers to create truly custom designs every time.

The benefit of using Faztek's service not only includes our turnkey services that will help you through every step of your products life cycle, but our friendly and knowledgeable staff is here to support you through the entire process. From the initial design through your projects final installation, we are here to help as much or as little as your team needs.

Faztek Contact Information

Phone: 260.482.7544

Fax: 260.482.7354

Toll-Free: 877.FAZTEK.4U
(329835.48)

Web: www.faztek.net

E-mail: insidesales@faztek.net